

STERIPEEL

Roll Holders with Cutting Device

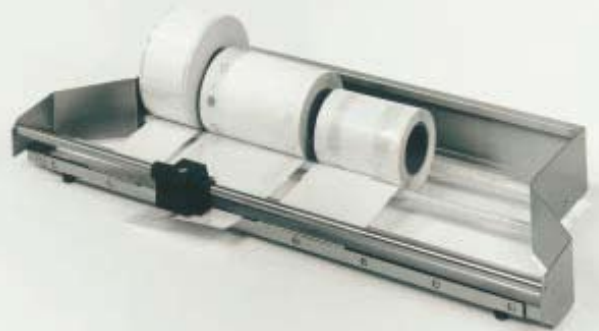

Competence in High Tech Sealing

- Chrome nickel steel 1.4301
- Self-sharpening cutting knife made from hardened steel
- Two steel rods with nylon bearings



famos
MEDIZINTECHNIK

Lot/Batch control (sterile)

Compressed liquids with stainless steel

Steam tapes 19-25-50 mm

Lot of gel with colored labels

Steam tapes 19-25-50 mm

Lot of gel with colored labels

Compressed liquids with stainless steel

Lot/Batch control (sterile)

Basic Disk Test Set

Medical Documentation (files & other technology)

Vacuum...for certainty!

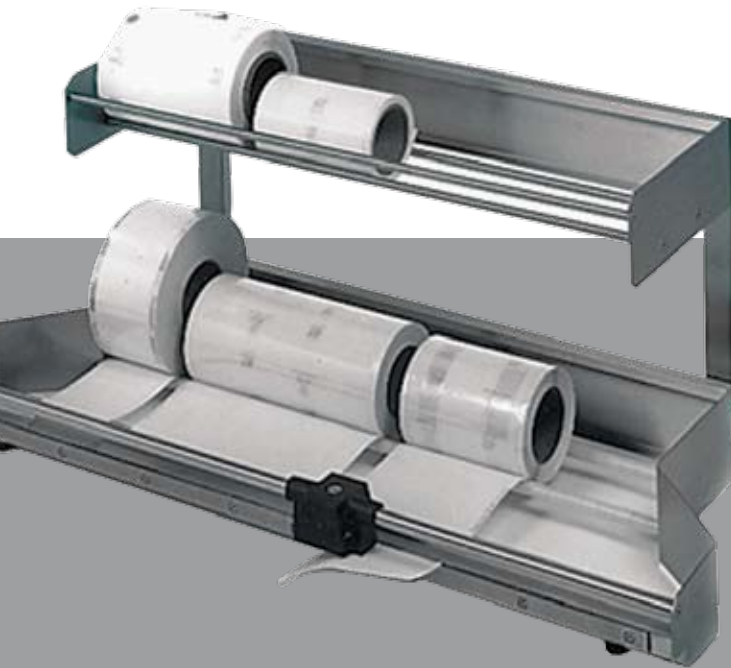

Roll holders of class and capacity

The standard packaging material used for packing medical devices sometimes does not meet with the sizes of the diversity in instruments. For this reason Famos has designed a roll holder including cutting device to create the length of packaging material which is required.

To store the rolls of laminate Famos has designed and developed a number of various stainless steel roll holders. These are equipped with a cutting device which enables the user to cut the laminate to the desired length.

The rotary knife of the cutting device is made from the highest quality hardened steel and is self-sharpening which ensures years of maintenance free use.

The Famos roll holders are available in various sizes. Furthermore an extension can be added which doubles the storage capacity of the holder. All roll holders are available as a table model, or in a version that can be attached to the wall or to the back of a work table or packing bench.

Technical Details

TYPE	Roll Holder with Cutting Device
MATERIAL	Chrome nickel steel 1.4301
ABOUT	Self sharpening cutting knife made from hardened steel Two steel rods with nylon bearings
F50.100.140	TS600 Reel Dispenser
Storage Capacity:	600mm
Dimensions:	(LxWxH) 820 x 420 x 130mm
F50.100.409	TS600 Reel Dispenser with Extension to Storage Capacity 1200mm
Dimensions:	(LxWxH) 820 x 420 x 420mm

Famos gives a one year manufacturers guarantee on all its products.

F50.100.080	TS750 Reel Dispenser
Storage Capacity:	750mm
Dimensions	(LxWxH) 970 x 420 x 130mm
F50.100.410	TS750 Reel Dispenser with Extension to Storage Capacity 1500m
Dimensions:	(LxWxH) 970 x 420 x 420mm
F50.100.130	TS900 Reel Dispenser
Storage Capacity:	900mm
Dimensions:	(LxWxH) 1120 x 420 x 130mm
F50.100.411	TS900 Reel Dispenser with Extension to Storage Capacity 1800m
Dimensions:	(LxWxH) 1120 x 420 x 420mm



CAPES MEDICAL LTD
 18 TUKORAKO DRIVE, MOUNT MAUNGANUI
 Phone 07 575 9777 | Fax 07 575 9333
 Email sales@capesmedical.co.nz | Web www.capesmedical.co.nz